

Performance Management (F5) September 2015 to June 2016

This syllabus and study guide is designed to help with planning study and to provide detailed information on what could be assessed in any examination session.

THE STRUCTURE OF THE SYLLABUS AND STUDY GUIDE

Relational diagram of paper with other papers

This diagram shows direct and indirect links between this paper and other papers preceding or following it. Some papers are directly underpinned by other papers such as Advanced Performance Management by Performance Management. These links are shown as solid line arrows. Other papers only have indirect relationships with each other such as links existing between the accounting and auditing papers. The links between these are shown as dotted line arrows. This diagram indicates where you are expected to have underpinning knowledge and where it would be useful to review previous learning before undertaking study.

Overall aim of the syllabus

This explains briefly the overall objective of the paper and indicates in the broadest sense the capabilities to be developed within the paper.

Main capabilities

This paper's aim is broken down into several main capabilities which divide the syllabus and study guide into discrete sections.

Relational diagram of the main capabilities

This diagram illustrates the flows and links between the main capabilities (sections) of the syllabus and should be used as an aid to planning teaching and learning in a structured way.

Syllabus rationale

This is a narrative explaining how the syllabus is structured and how the main capabilities are linked. The rationale also explains in further detail what the examination intends to assess and why.

Detailed syllabus

This shows the breakdown of the main capabilities (sections) of the syllabus into subject areas. This is the blueprint for the detailed study guide.

Approach to examining the syllabus

This section briefly explains the structure of the examination and how it is assessed.

Study Guide

This is the main document that students, learning and content providers should use as the basis of their studies, instruction and materials. Examinations will be based on the detail of the study guide which comprehensively identifies what could be assessed in any examination session. The study guide is a precise reflection and breakdown of the syllabus. It is divided into sections based on the main capabilities identified in the syllabus. These sections are divided into subject areas which relate to the sub-capabilities included in the detailed syllabus. Subject areas are broken down into sub-headings which describe the detailed outcomes that could be assessed in examinations. These outcomes are described using verbs indicating what exams may require students to demonstrate, and the broad intellectual level at which these may need to be demonstrated (*see intellectual levels below).

Learning Materials

ACCA's Approved Content Programme is the programme through which ACCA approves learning materials from high quality content providers designed to support study towards ACCA's qualifications.

ACCA has three Approved Content Providers, Becker Professional Education, BPP Learning Media and Kaplan Publishing.

For information about ACCA's Approved Content Providers please go to ACCA's Content Provider Directory.

The Directory also lists materials by other publishers, these materials have not been quality assured by ACCA but may be helpful if used in conjunction with approved learning materials or for variant exams where no approved content is available. You will also find details of Additional Reading suggested by the examining teams and this may be a useful supplement to approved learning materials.

ACCA's Content Provider Directory can be found here – <http://www.accaglobal.com/uk/en/student/acca-qual-student-journey/study-revision/learning-providers/alp-content.html>

Relevant articles are also published in Student Accountant and available on the ACCA website.

INTELLECTUAL LEVELS

The syllabus is designed to progressively broaden and deepen the knowledge, skills and professional values demonstrated by the student on their way through the qualification.

The specific capabilities within the detailed syllabuses and study guides are assessed at one of three intellectual or cognitive levels:

Level 1: Knowledge and comprehension
Level 2: Application and analysis
Level 3: Synthesis and evaluation

Very broadly, these intellectual levels relate to the three cognitive levels at which the Knowledge module, the Skills module and the Professional level are assessed.

Each subject area in the detailed study guide included in this document is given a 1, 2, or 3 superscript, denoting intellectual level, marked at the end of each relevant line. This gives an indication of the intellectual depth at which an area could be assessed within the examination. However, while level 1 broadly equates with the Knowledge module, level 2 equates to the Skills module and level 3 to the Professional level, some lower level skills can continue to be assessed as the student

progresses through each module and level. This reflects that at each stage of study there will be a requirement to broaden, as well as deepen capabilities. It is also possible that occasionally some higher level capabilities may be assessed at lower levels.

LEARNING HOURS AND EDUCATION RECOGNITION

The ACCA qualification does not prescribe or recommend any particular number of learning hours for examinations because study and learning patterns and styles vary greatly between people and organisations. This also recognises the wide diversity of personal, professional and educational circumstances in which ACCA students find themselves.

As a member of the International Federation of Accountants, ACCA seeks to enhance the education recognition of its qualification on both national and international education frameworks, and with educational authorities and partners globally. In doing so, ACCA aims to ensure that its qualifications are recognized and valued by governments, regulatory authorities and employers across all sectors. To this end, ACCA qualifications are currently recognized on the education frameworks in several countries. Please refer to your national education framework regulator for further information.

Each syllabus contains between 23 and 35 main subject area headings depending on the nature of the subject and how these areas have been broken down.

GUIDE TO EXAM STRUCTURE

The structure of examinations varies within and between modules and levels.

The Fundamentals level examinations contain 100% compulsory questions to encourage candidates to study across the breadth of each syllabus.

The Knowledge module is assessed by equivalent two-hour paper based and computer based examinations.

The Skills module examinations F5-F9 are all paper

based three-hour papers containing a mix of objective and longer type questions.

The *Corporate and Business Law* (F4) paper is a two-hour computer based objective test examination which is also available as a paper based version from the December 2014 examination session.

The Professional level papers are all three-hour paper based examinations, all containing two sections. Section A is compulsory, but there will be some choice offered in Section B.

For all three hour examination papers, ACCA has introduced 15 minutes reading and planning time.

This additional time is allowed at the beginning of each three-hour examination to allow candidates to read the questions and to begin planning their answers before they start writing in their answer books. This time should be used to ensure that all the information and exam requirements are properly read and understood.

During reading and planning time candidates may only annotate their question paper. They may not write anything in their answer booklets until told to do so by the invigilator.

The Essentials module papers all have a Section A containing a major case study question with all requirements totalling 50 marks relating to this case. Section B gives students a choice of two from three 25 mark questions.

Section A of both the P4 and P5 Options papers contain one 50 mark compulsory question, and Section B will offer a choice of two from three questions each worth 25 marks each.

Section A of each of the P6 and P7 Options papers contains 60 compulsory marks from two questions; question 1 attracting 35 marks, and question 2 attracting 25 marks. Section B of both these Options papers will offer a choice of two from three questions, with each question attracting 20 marks.

All Professional level exams contain four professional marks.

The pass mark for all ACCA Qualification examination papers is 50%.

GUIDE TO EXAMINATION ASSESSMENT

ACCA reserves the right to examine anything contained within the study guide at any examination session. This includes knowledge, techniques, principles, theories, and concepts as specified.

For the financial accounting, audit and assurance, law and tax papers except where indicated otherwise, ACCA will publish *examinable documents* once a year to indicate exactly what regulations and legislation could potentially be assessed within identified examination sessions..

For paper based examinations regulation *issued* or legislation *passed* on or before 31st August annually, will be examinable from 1st September of the following year to 31st August of the year after that. Please refer to the examinable documents for the paper (where relevant) for further information.

Regulation issued or legislation passed in accordance with the above dates may be examinable even if the *effective* date is in the future.

The term issued or passed relates to when regulation or legislation has been formally approved.

The term effective relates to when regulation or legislation must be applied to an entity transactions and business practices.

The study guide offers more detailed guidance on the depth and level at which the examinable documents will be examined. The study guide should therefore be read in conjunction with the examinable documents list.

Syllabus

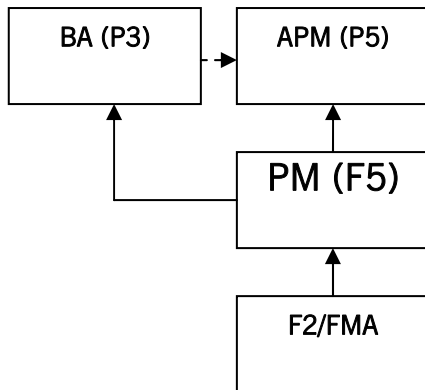

AIM

To develop knowledge and skills in the application of management accounting techniques to quantitative and qualitative information for planning, decision-making, performance evaluation, and control

MAIN CAPABILITIES

On successful completion of this paper, candidates should be able to:

- A** Explain and apply cost accounting techniques
- B** Select and appropriately apply decision-making techniques to facilitate business decisions and promote efficient and effective use of scarce business resources, appreciating the risks and uncertainty inherent in business and controlling those risks
- C** Identify and apply appropriate budgeting techniques and methods for planning and control and use standard costing systems to measure and control business performance and to identify remedial action
- D** Identify and discuss performance management information and measurement systems and assess the performance of an organisation from both a financial and non-financial viewpoint, appreciating the problems of controlling divisionalised businesses and the importance of allowing for external aspects

RELATIONAL DIAGRAM OF MAIN CAPABILITIES

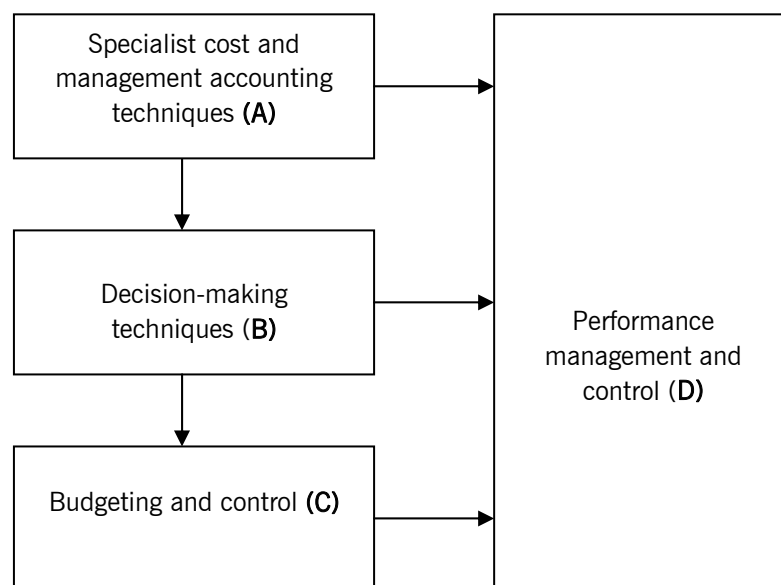

RATIONALE

The syllabus for Paper F5, *Performance Management*, builds on the knowledge gained in Paper F2, *Management Accounting*, and seek to examine candidates' understanding of how to manage the performance of a business. It also prepares candidates for more specialist capabilities which are covered in P5 *Advanced Performance Management*.

The syllabus begins by introducing more specialised management accounting topics. There is some knowledge assumed from Paper F2 – primarily overhead treatments. The objective here is to ensure candidates have a broader background in management accounting techniques.

The syllabus then considers decision-making. Candidates need to appreciate the problems surrounding scarce resource, pricing and make-or-buy decisions, and how this relates to the assessment of performance. Risk and uncertainty are a factor of real-life decisions and candidates need to understand risk and be able to apply some basic methods to help resolve the risks inherent in decision-making.

Budgeting is an important aspect of many accountants' lives. The syllabus explores different budgeting techniques and the problems inherent in them. The behavioural aspects of budgeting are important for accountants to understand, and the syllabus includes consideration of the way individuals react to a budget. The preparation of fixed, flexible and incremental budgets is assumed knowledge from F2.

Standard costing and variances are then built on. All the variances examined in Paper F2 are assumed knowledge in F5. Mix and yield variances, and planning and operational variances are explored here and the link is made to performance management. It is important for accountants to be able to interpret the numbers that they calculate and ask what they mean in the context of performance.

The syllabus concludes with performance management systems, measurement and control. This is a major area of the syllabus. Accountants need to understand how a business should be managed and controlled and how information

systems can be used to facilitate this. They should appreciate the importance of both financial and non-financial performance measures in management. Accountants should also appreciate the difficulties in assessing performance in divisionalised businesses and the problems caused by failing to consider external influences on performance. This section leads directly to Paper P5.

All of the subject areas covered in this syllabus could be examined in either a public sector or private sector context.

DETAILED SYLLABUS

A Specialist cost and management accounting techniques

1. Activity-based costing
2. Target costing
3. Life-cycle costing
4. Throughput accounting
5. Environmental accounting

B Decision-making techniques

1. Relevant cost analysis
2. Cost volume analysis
3. Limiting factors
4. Pricing decisions
5. Make-or-buy and other short-term decisions
6. Dealing with risk and uncertainty in decision-making

C Budgeting and control

- 1 Budgetary systems
2. Types of budget
3. Quantitative analysis in budgeting
- 4 Standard costing
- 5 Material mix and yield variances
- 6 Sales mix and quantity variances
7. Planning and operational variances
- 8 Performance analysis and behavioural aspects

D Performance measurement and control

1. Performance management information systems
2. Sources of management information
3. Management reports
4. Performance analysis in private sector organisations
5. Divisional performance and transfer pricing
6. Performance analysis in not-for-profit organisations and the public sector
7. External considerations and behavioural aspects

APPROACH TO EXAMINING THE SYLLABUS

The syllabus is assessed by a three-hour paper-based examination.

All questions are compulsory. It will contain both computational and discursive elements. Some questions will adopt a scenario/case study approach.

Section A of the exam comprises 20 multiple choice questions of 2 marks each.

Section B of the exam comprises three 10 mark questions and two 15 mark questions.

The two 15 mark questions will come from decision making techniques, budgeting and control and/or performance measurement and control areas of the syllabus. The section A questions and the other questions in section B can cover any areas of the syllabus.

Candidates are provided with a formulae sheet

Study Guide

A SPECIALIST COST AND MANAGEMENT ACCOUNTING TECHNIQUES

1. Activity based costing

- a) Identify appropriate cost drivers under ABC.^[1]
- b) Calculate costs per driver and per unit using ABC.^[2]
- c) Compare ABC and traditional methods of overhead absorption based on production units, labour hours or machine hours.^[2]

2. Target costing

- a) Derive a target cost in manufacturing and service industries.^[2]
- b) Explain the difficulties of using target costing in service industries.^[2]
- c) Suggest how a target cost gap might be closed.^[2]

3. Life-cycle costing

- a) Identify the costs involved at different stages of the life-cycle.^[2]
- b) Derive a life cycle cost in manufacturing and service industries.^[2]
- c) Identify the benefits of life cycle costing.^[2]

4. Throughput accounting

- a) Discuss and apply the theory of constraints.^[2]
- b) Calculate and interpret a throughput accounting ratio (TPAR).^[2]
- c) Suggest how a TPAR could be improved.^[2]
- d) Apply throughput accounting to a multi-product decision-making problem.^[2]

5. Environmental accounting

- a) Discuss the issues business face in the management of environmental costs.^[1]

- b) Describe the different methods a business may use to account for its environmental costs.^[1]

B DECISION-MAKING TECHNIQUES

1 Relevant cost analysis

- a) Explain the concept of relevant costing.^[2]
- b) Identify and calculate relevant costs for a specific decision situations from given data.^[2]
- c) Explain and apply the concept of opportunity costs.^[2]

2. Cost volume profit analysis

- a) Explain the nature of CVP analysis.^[2]
- b) Calculate and interpret break even point and margin of safety.^[2]
- c) Calculate the contribution to sales ratio, in single and multi-product situations, and demonstrate an understanding of its use.^[2]
- d) Calculate target profit or revenue in single and multi-product situations, and demonstrate an understanding of its use.^[2]
- e) Prepare break even charts and profit volume charts and interpret the information contained within each, including multi-product situations.^[2]
- f) Discuss the limitations of CVP analysis for planning and decision making.^[2]

3. Limiting factors

- a) Identify limiting factors in a scarce resource situation and select an appropriate technique.^[2]
- b) Determine the optimal production plan where an organisation is restricted by a single limiting factor, including within the context of “make” or “buy” decisions.^[2]
- c) Formulate and solve multiple scarce resource problem both graphically and using simultaneous equations as appropriate.^[2]

- d) Explain and calculate shadow prices (dual prices) and discuss their implications on decision-making and performance management.^[2]
- e) Calculate slack and explain the implications of the existence of slack for decision-making and performance management.^[2] (Excluding simplex and sensitivity to changes in objective functions)

4. Pricing decisions

- a) Explain the factors that influence the pricing of a product or service.^[2]
- b) Explain the price elasticity of demand.^[1]
- c) Derive and manipulate a straight line demand equation. Derive an equation for the total cost function (including volume-based discounts).^[2]
- d) Calculate the optimum selling price and quantity for an organisation, equating marginal cost and marginal revenue.^[2]
- e) Evaluate a decision to increase production and sales levels, considering incremental costs, incremental revenues and other factors.^[2]
- f) Determine prices and output levels for profit maximisation using the demand based approach to pricing (both tabular and algebraic methods).^[1]
- g) Explain different price strategies, including:^[2]
 - i) All forms of cost-plus
 - ii) Skimming
 - iii) Penetration
 - iv) Complementary product
 - v) Product-line
 - vi) Volume discounting
 - vii) Discrimination
 - viii) Relevant cost
- h) Calculate a price from a given strategy using cost-plus and relevant cost.^[2]

5. Make-or-buy and other short-term decisions

- a) Explain the issues surrounding make vs. buy and outsourcing decisions.^[2]

- b) Calculate and compare “make” costs with “buy-in” costs.^[2]
- c) Compare in-house costs and outsource costs of completing tasks and consider other issues surrounding this decision.^[2]
- d) Apply relevant costing principles in situations involving shut down, one-off contracts and the further processing of joint products.^[2]

6. Dealing with risk and uncertainty in decision-making

- a) Suggest research techniques to reduce uncertainty e.g. Focus groups, market research.^[2]
- b) Explain the use of simulation, expected values and sensitivity.^[1]
- c) Apply expected values and sensitivity to decision-making problems.^[2]
- d) Apply the techniques of maximax, maximin, and minimax regret to decision-making problems including the production of profit tables.^[2]
- e) Draw a decision tree and use it to solve a multi-stage decision problem
- f) Calculate the value of perfect and imperfect information.

C BUDGETING AND CONTROL

1. Budgetary systems

- a) Explain how budgetary systems fit within the performance hierarchy.^[2]
- b) Select and explain appropriate budgetary systems for an organisation, including top-down, bottom-up, rolling, zero-base, activity-base, incremental and feed-forward control.^[2]
- c) Describe the information used in budget systems and the sources of the information needed.^[2]
- d) Explain the difficulties of changing a budgetary system.^[2]

- e) Explain how budget systems can deal with uncertainty in the environment.^[2]

2. Types of Budget

- a) Prepare rolling budgets and activity based budgets.^[2]
- b) Indicate the usefulness and problems with different budget types (including fixed, flexible, zero-based, activity-based, incremental, rolling, top-down, bottom up, master, functional).^[2]
- c) Explain the difficulties of changing the type of budget used.^[2]

3. Quantitative analysis in budgeting

- a) Analyse fixed and variable cost elements from total cost data using high/low method.
- b) Estimate the learning rate and learning effect^[2]
- c) Apply the learning curve to a budgetary problem, including calculations on steady states^[2]
- d) Discuss the reservations with the learning curve.^[2]
- e) Apply expected values and explain the problems and benefits.^[2]
- f) Explain the benefits and dangers inherent in using spreadsheets in budgeting.^[2]

4. Standard costing

- a) Explain the use of standard costs.^[2]
- b) Outline the methods used to derive standard costs and discuss the different types of cost possible.^[2]
- c) Explain and illustrate the importance of flexing budgets in performance management.^[2]
- d) Explain and apply the principle of controllability in the performance management system.^[2]

5. Material mix and yield variances

- a) Calculate, identify the cause of, and explain material mix and yield variances.^[2]
- b) Explain the wider issues involved in changing material mix e.g. cost, quality and performance measurement issues.^[2]
- c) Identify and explain the relationship of the material usage variance with the material mix and yield variances.^[2]
- d) Suggest and justify alternative methods of controlling production processes.^[2]

6. Sales mix and quantity variances

- a) Calculate, identify the cause of, and explain sales mix and quantity variances.^[2]
- b) Identify and explain the relationship of the sales volume variances with the sales mix and quantity variances.^[2]

7. Planning and operational variances

- a) Calculate a revised budget.^[2]
- b) Identify and explain those factors that could and could not be allowed to revise an original budget.^[2]
- c) Calculate, identify the cause of and explain planning and operational variances for:
 - i) sales, including market size and market share;
 - ii) materials;
 - iii) labour, including the effect of the learning curve.^[2]
- d) Explain and discuss the manipulation issues involved in revising budgets.^[2]

8. Performance analysis and behavioural aspects

- a) Analyse and evaluate past performance using the results of variance analysis.^[2]
- b) Use variance analysis to assess how future performance of an organisation or business can be improved.^[2]

- c) Identify the factors which influence behaviour.^[2]
- d) Discuss the issues surrounding setting the difficulty level for a budget.^[2]
- e) Discuss the effect that variances have on staff motivation and action.^[2]
- f) Explain the benefits and difficulties of the participation of employees in the negotiation of targets.^[2]
- g) Describe the dysfunctional nature of some variances in the modern environment of JIT and TQM.^[2]
- h) Discuss the behavioural problems resulting from using standard costs in rapidly changing environments.^[2]

D PERFORMANCE MEASUREMENT AND CONTROL

1. Performance management information systems

- a) Identify the accounting information requirements and describe the different types of information systems used for strategic planning, management control and operational control and decision-making.^[2]
- b) Define and identify the main characteristics of transaction processing systems; management information systems; executive information systems; and enterprise resource planning systems.^[2]
- c) Define and discuss the merits of, and potential problems with, open and closed systems with regard to the needs of performance management.^[2]

2. Sources of management information

- a) Identify the principal internal and external sources of management accounting information.^[2]
- b) Demonstrate how these principal sources of management information might be used for control purposes.^[2]

- c) Identify and discuss the direct data capture and process costs of management accounting information.^[2]
- d) Identify and discuss the indirect costs of producing information.^[2]
- e) Discuss the limitations of using externally generated information.^[2]

3. Management reports

- a) Discuss the principal controls required in generating and distributing internal information.^[2]
- b) Discuss the procedures that may be necessary to ensure security of highly confidential information that is not for external consumption.^[2]

4. Performance analysis in private sector organisations

- a) Describe, calculate and interpret financial performance indicators (FPIs) for profitability, liquidity and risk in both manufacturing and service businesses. Suggest methods to improve these measures.^[2]
- b) Describe, calculate and interpret non-financial performance indicators (NFPIs) and suggest method to improve the performance indicated.^[2]
- c) Analyse past performance and suggest ways for improving financial and non-financial performance.^[2]
- d) Explain the causes and problems created by short-termism and financial manipulation of results and suggest methods to encourage a long term view.^[2]
- e) Explain and interpret the Balanced Scorecard, and the Building Block model proposed by Fitzgerald and Moon.^[2]
- f) Discuss the difficulties of target setting in qualitative areas.^[2]

5. Divisional performance and transfer pricing

- a) Explain and illustrate the basis for setting a transfer price using variable cost, full cost and the principles behind allowing for intermediate markets.^[2]
- b) Explain how transfer prices can distort the performance assessment of divisions and decisions made.^[2]
- c) Explain the meaning of, and calculate, Return on Investment (ROI) and Residual Income (RI), and discuss their shortcomings.^[2]
- d) Compare divisional performance and recognise the problems of doing so.^[2]

6. Performance analysis in not for profit organisations and the public sector

- a) Comment on the problems of having non-quantifiable objectives in performance management.^[2]
- b) Explain how performance could be measured in this sector.^[2]
- c) Comment on the problems of having multiple objectives in this sector.^[2]
- d) Outline Value for Money (VFM) as a public sector objective.^[1]

7. External considerations and behavioural aspects

- a) Explain the need to allow for external considerations in performance management, including stakeholders, market conditions and allowance for competitors.^[2]
- b) Suggest ways in which external considerations could be allowed for in performance management.^[2]
- c) Interpret performance in the light of external considerations.^[2]
- d) Identify and explain the behaviour aspects of performance management ^[2]

SUMMARY OF CHANGES TO F5

ACCA periodically reviews its qualification syllabuses so that they fully meet the needs of stakeholders such as employers, students, regulatory and advisory bodies and learning providers.

There were no deletions or additions to the F5 syllabus.